

15-40W Medical AC-DC PCB-Mount Power Supplies

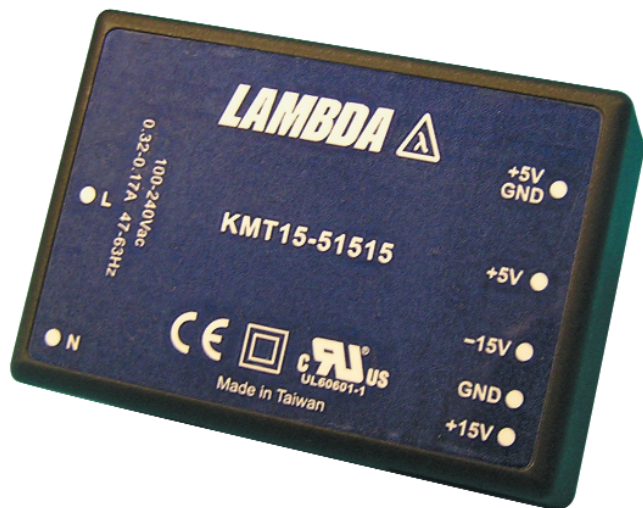

- ◆ Small size and lightweight
- ◆ PC Board Mountable
- ◆ Wide Range Input
- ◆ Medical Safety Certifications (4kVAC Input - Output)
- ◆ Class II (No ground needed)

RoHS

Features and Benefits

Feature	Benefit
◆ Small size	◆ Minimizes pcb space
◆ Wide input range	◆ Global use with no manual intervention
◆ High efficiency	◆ Lower heat dissipated in system

Specifications

MODELS		KMS15	KMD15	KMT15	KMS40	KMD40	KMT40
ITEMS							
Input Voltage Range	-	90-264VAC 47-440Hz or 100-375VDC					
Inrush Current Limiting	A	10 / 20A, cold start, 25°C ambient (115 / 230VAC)					
Input Current (115 / 230VAC)	mA	220 / 118mA			860 / 460mA		
Recommended External Fuse	-	2A slow blow type			3.15A slow blow type		
Temperature Coefficient	-	±0.01%/°C					
Ripple and Noise (pk-pk)	mV	50mV or 1%, whichever is greater					
Overcurrent Protection	-	> 105%, hiccup mode, automatic recovery					
Overvoltage Protection	%	Yes, Zener diode clamp					
Hold-up Time (typical)	ms	20ms			18ms		
Enclosure Leakage (240VAC 63Hz) (264VAC 63Hz)	mA	0.055 max 0.06 max			0.08 max 0.085 max		
Operating Temperature	-	-25°C to 70°C, derate linearly to 50% load from 50°C to 70°C. Max case temperature 95°C					
Storage Temperature	-	-40°C to 100°C					
Humidity	%RH	20% to 95% RH (non-condensing)					
Cooling	-	Convection, over temperature protected ~100°C case temperature)					
Withstand Voltage	VAC	Input to output: 4kVAC					
Immunity	-	EN60601-1-2					
Safety Agency Certification	-	UL60601-1, IEC60601-1, CE Mark, EN60950-1					
Conducted EMI	-	EN55011, EN55022 Class B			EN55011, EN55022 Class A		
Switching Frequency	kHz				132kHz		
Weight	g	120			280		
Size (LxWxH)	in	2.52 x 1.79 x 0.92"			3.5 x 2.5 x 1.06"		
Mounting & Case	-	PC board mountable. Plastic resin fiberglass case (UL 94V-0)					
MTBF	hrs	200,000 to 400,000 hours, model dependant					
Warranty	yrs	2 years					

Output Ratings

Model	Output Voltage (V)	Minimum Current (A)	Maximum Current (A)	Power (W)	Output Set Accuracy (%)	Line Regulation (%)	Load Regulation (1) (%)	Cross Regulation	Efficiency (%)	
Single Output										
KMS15-3P3	V1	3.3V	0A	3.00A	9.9W	±2%	0.5%	1%	-	74%
KMS40-3P3	V1	3.3V	80mA	8.00A	26.4W	±2%	0.5%	1%	-	75%
KMS15-5	V1	5V	0A	3.00A	15W	±2%	0.5%	1%	-	78%
KMS40-5	V1	5V	80mA	8.00A	40W	±2%	0.5%	1%	-	79%
KMS15-9	V1	9V	0A	1.67A	15W	±2%	0.5%	1%	-	79%
KMS40-9	V1	9V	44mA	4.44A	40W	±2%	0.5%	1%	-	82%
KMS15-12	V1	12V	0A	1.25A	15W	±2%	0.5%	1%	-	81%
KMS40-12	V1	12V	33mA	3.33A	40W	±2%	0.5%	1%	-	83%
KMS15-15	V1	15V	0A	1.00A	15W	±2%	0.5%	1%	-	81%
KMS40-15	V1	15V	26.7mA	2.67A	40W	±2%	0.5%	1%	-	83%
KMS15-24	V1	24V	0A	0.62A	15W	±2%	0.5%	1%	-	83%
KMS40-24	V1	24V	16.7mA	1.67A	40W	±2%	0.5%	1%	-	83%
Dual Output										
KMD15-55	V1	+5V	150mA	1.5A	15W	±2%	0.5%	1%	5%	78%
	V2	-5V	150mA	1.5A		±2%	0.5%	1%	5%	
KMD40-55	V1	+5V	400mA	4A	40W	±2%	0.5%	1%	5%	79%
	V2	-5V	400mA	4A		±2%	0.5%	1%	5%	
KMD40-512	V1	5V(2)	1250mA	5A	40W	±3%	0.5%	2%	1%	80%
	V2	12V(2)	312mA	1.25A		±5%	5.0%	6%	7%	
KMD40-524	V1	5V(2)	1250mA	5A	40W	±3%	0.5%	2%	1%	80%
	V2	24V(2)	156mA	0.625A		±5%	5.0%	6%	7%	
KMD15-1212	V1	+12V	62.5mA	0.625A	15W	±2%	0.5%	1%	3%	80%
	V2	-12V	62.5mA	0.625A		±2%	0.5%	1%	3%	
KMD40-1212	V1	+12V	166mA	1.66A	40W	±2%	0.5%	1%	5%	83%
	V2	-12V	166mA	1.66A		±2%	0.5%	1%	5%	
KMD15-1515	V1	+15V	50mA	0.5A	15W	±2%	0.5%	1%	3%	81%
	V2	-15V	50mA	0.5A		±2%	0.5%	1%	3%	
KMD40-1515	V1	+15V	133mA	1.33A	40W	±2%	0.5%	1%	5%	81%
	V2	-15V	133mA	1.33A		±2%	0.5%	1%	5%	
Triple Output										
KMT15-51212	V1	5V(3)	500mA	2A	15W	±2%	0.5%	1%	1%	78%
	V2	+12V	50mA	0.2A		±3%	2.0%	5%	5%	
	V3	-12V	50mA	0.2A		±3%	2.0%	5%	5%	
KMT40-51212	V1	5V(3)	1250mA	5A	40W	±3%	0.5%	3%	3%	80%
	V2	+12V	150mA	0.6A		±5%	5.0%	7%	7%	
	V3	-12V	150mA	0.6A		±5%	5.0%	7%	7%	
KMT15-51515	V1	5V(3)	500mA	2A	15W	±2%	0.5%	1%	1%	78%
	V2	+15V	37.5mA	0.15A		±3%	2.0%	5%	5%	
	V3	-15V	37.5mA	0.15A		±3%	2.0%	5%	5%	
KMT40-51515	V1	5V(3)	1250mA	5A	40W	±3%	0.5%	3%	3%	80%
	V2	+15V	125mA	0.5A		±5%	5.0%	7%	7%	
	V3	-15V	125mA	0.5A		±5%	5.0%	7%	7%	

KM15 Outline Drawings

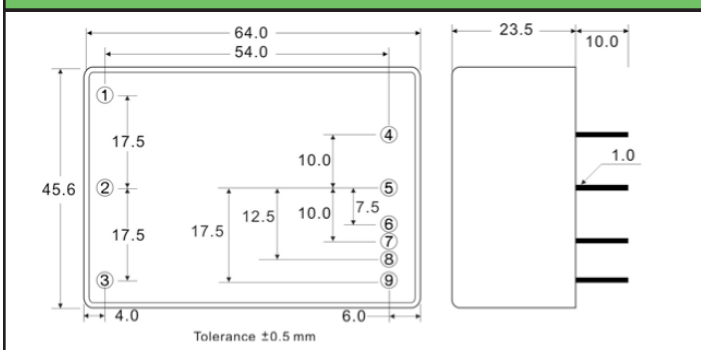

- (1) Symmetrical loading, from minimum to maximum load
- (2) Output V1 is isolated from output V2
- (3) Output V1 is isolated from outputs V2 & V3

KM40 Outline Drawings



For Additional Information, please visit
us.tdk-lambda.com/lp/products/km-series.htm